



METER

ATMOS 41 INTEGRATOR GUIDE

SENSOR DESCRIPTION

The ATMOS 41 All-in-One Weather Station is designed for continuous monitoring of environmental variables, including all standard weather measurements (see [Measurement Specifications](#)). All sensors are integrated into a single unit, requiring minimal installation effort. Ultra-low power consumption and a robust, no moving parts design that prevents errors because of wear or fouling make the ATMOS 41 ideal for long-term, remote installations.

APPLICATIONS

- Weather monitoring
- Microenvironment monitoring
- Spatially distributed environmental monitoring
- Crop weather monitoring
- Fire danger monitoring/mapping
- Weather networks

ADVANTAGES

- Robust, no moving parts design
- Small form factor
- Integrated design for easy installation
- Low-input voltage requirements
- Low-power design supports battery-operated data loggers
- Supports the SDI-12 three-wire interface
- Tilt sensor informs user of out-of-level conditions
- No configuration necessary
- Measures all standard weather variables (plus several others)

PURPOSE OF THIS GUIDE

METER Group provides the information in this integrator's guide to help ATMOS 41 All-in-One Weather Station customers establish communication between these sensors and their data acquisition equipment or field data loggers. Customers using data loggers that support SDI-12 sensor communications should consult the data logger user manual. METER sensors are fully integrated into the METER system of plug-and-play sensors, cellular-enabled data loggers, and data analysis software.

COMPATIBLE FIRMWARE VERSIONS

This guide is compatible with firmware versions 5.30 or newer.

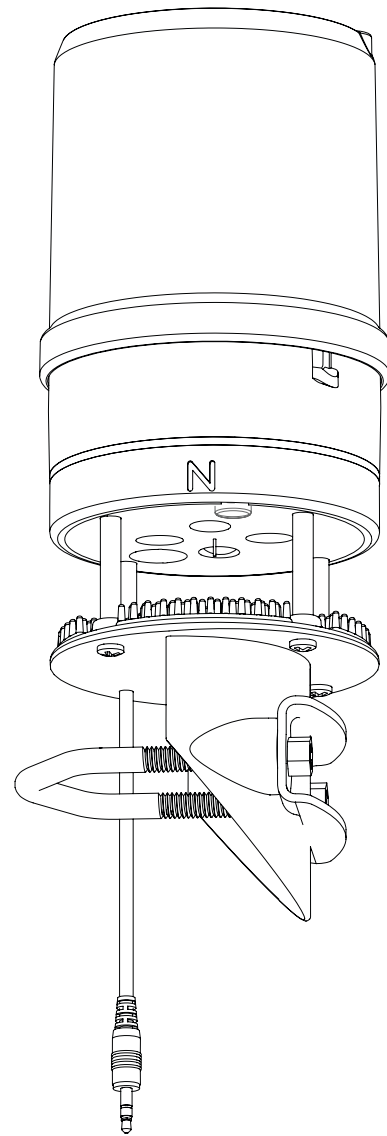

Figure 1 ATMOS 41 All-in-One Weather Station

SPECIFICATIONS

MEASUREMENT SPECIFICATIONS

Solar Radiation	
Range	0–1750 W/m ²
Resolution	1 W/m ²
Accuracy	±5% of measurement typical

Precipitation	
Range	0–400 mm/h
Resolution	0.017 mm
Accuracy	±5% of measurement from 0 to 50 mm/h

Vapor Pressure	
Range	0–47 kPa
Resolution	0.01 kPa
Accuracy	Varies with temperature and humidity, ±0.2 kPa typical below 40 °C

HUMIDITY (%RH)	TEMPERATURE (°C)								
	0°C	10°C	20°C	30°C	40°C	50°C	60°C	70°C	80°C
100%	±0.05	±0.09	±0.16	±0.29	±0.49	±0.81	±1.30	±2.62	±6.32
95%	±0.05	±0.09	±0.14	±0.24	±0.41	±0.68	±1.08	±2.26	±5.27
90%	±0.05	±0.07	±0.09	±0.15	±0.33	±0.54	±1.06	±2.23	±5.20
85%	±0.05	±0.07	±0.08	±0.15	±0.33	±0.53	±1.05	±2.19	±5.13
80%	±0.04	±0.07	±0.08	±0.15	±0.32	±0.53	±0.83	±1.84	±4.07
75%	±0.04	±0.07	±0.08	±0.14	±0.31	±0.52	±0.82	±1.80	±4.00
70%	±0.04	±0.07	±0.08	±0.14	±0.31	±0.51	±0.81	±1.77	±3.93
65%	±0.04	±0.07	±0.08	±0.13	±0.30	±0.50	±0.79	±1.73	±3.86
60%	±0.04	±0.05	±0.07	±0.13	±0.22	±0.36	±0.57	±1.38	±3.30
55%	±0.04	±0.04	±0.07	±0.13	±0.22	±0.35	±0.56	±1.34	±3.23
50%	±0.03	±0.04	±0.07	±0.12	±0.21	±0.34	±0.55	±1.31	±3.16
45%	±0.03	±0.04	±0.07	±0.12	±0.20	±0.33	±0.53	±1.27	±2.80
40%	±0.03	±0.03	±0.07	±0.12	±0.20	±0.33	±0.52	±1.24	±2.53
35%	±0.03	±0.05	±0.06	±0.11	±0.19	±0.32	±0.50	±1.20	±2.46
30%	±0.03	±0.05	±0.06	±0.11	±0.19	±0.31	±0.49	±1.17	±2.39
25%	±0.03	±0.04	±0.06	±0.10	±0.18	±0.30	±0.48	±1.14	±2.32
20%	±0.03	±0.06	±0.06	±0.10	±0.25	±0.41	±0.67	±1.10	±2.25
15%	±0.03	±0.05	±0.05	±0.10	±0.24	±0.40	±0.85	±1.39	±2.67
10%	±0.05	±0.07	±0.08	±0.14	±0.31	±0.52	±0.84	±1.67	±4.08
5%	±0.05	±0.10	±0.12	±0.22	±0.38	±0.64	±1.03	±1.96	±5.00
0%	±0.08	±0.15	±0.12	±0.22	±0.45	±0.75	±1.22	±3.21	±5.92

Relative Humidity	
Range	0–100% RH (0.00–1.00)
Resolution	0.1% RH
Accuracy	Varies with temperature and humidity, ±3% RH typical

HUMIDITY (%RH)	TEMPERATURE (°C)								
	0°C	10°C	20°C	30°C	40°C	50°C	60°C	70°C	80°C
100%	±5%	±5%	±5%	±5%	±5%	±5%	±5%	±6%	±10%
95%	±5%	±5%	±4%	±4%	±4%	±4%	±4%	±5%	±8%
90%	±5%	±4%	±2%	±2%	±3%	±3%	±4%	±5%	±8%
85%	±5%	±4%	±2%	±2%	±3%	±3%	±4%	±5%	±8%
80%	±4%	±4%	±2%	±2%	±3%	±3%	±3%	±4%	±6%
75%	±4%	±4%	±2%	±2%	±3%	±3%	±3%	±4%	±6%
70%	±4%	±4%	±2%	±2%	±3%	±3%	±3%	±4%	±6%
65%	±4%	±4%	±2%	±2%	±3%	±3%	±3%	±4%	±6%
60%	±4%	±3%	±2%	±2%	±2%	±2%	±2%	±3%	±5%
55%	±4%	±2%	±2%	±2%	±2%	±2%	±2%	±3%	±5%
50%	±4%	±2%	±2%	±2%	±2%	±2%	±2%	±3%	±5%
45%	±4%	±2%	±2%	±2%	±2%	±2%	±2%	±3%	±4%
40%	±4%	±2%	±2%	±2%	±2%	±2%	±2%	±3%	±4%
35%	±4%	±3%	±2%	±2%	±2%	±2%	±2%	±3%	±4%
30%	±4%	±3%	±2%	±2%	±2%	±2%	±2%	±3%	±4%
25%	±4%	±3%	±2%	±2%	±2%	±2%	±2%	±3%	±4%
20%	±4%	±4%	±2%	±2%	±3%	±3%	±3%	±4%	±6%
15%	±5%	±4%	±2%	±2%	±3%	±3%	±4%	±4%	±5%
10%	±8%	±5%	±3%	±3%	±4%	±4%	±4%	±5%	±8%
5%	±8%	±8%	±5%	±5%	±5%	±5%	±5%	±6%	±10%
0%	±12%	±12%	±5%	±5%	±6%	±6%	±6%	±10%	±12%

Air Temperature	
Range	–50 to 60 °C
Resolution	0.1 °C
Accuracy	±0.6 °C

Humidity Sensor Temperature	
Range	–40 to 50 °C
Resolution	0.1 °C
Accuracy	±1.0 °C

Barometric Pressure	
Range	50–110 kPa
Resolution	0.01 kPa
Accuracy	±0.1 kPa from –10 to 50 °C ±0.5 kPa from –40 to 60 °C

Horizontal Wind Speed	
Range	0–30 m/s
Resolution	0.01 m/s
Accuracy	The greater of 0.3 m/s or 3% of measurement

Wind Gust	
Range	0–30 m/s
Resolution	0.01 m/s
Accuracy	The greater of 0.3 m/s or 3% of measurement

Wind Direction	
Range	0°–359°
Resolution	1°
Accuracy	±5°

Tilt	
Range	–90° to 90°
Resolution	0.1°
Accuracy	±1°

Lightning Strike Count	
Range	0–65,535 strikes
Resolution	1 strike
Accuracy	Variable with distance, >25% detection at <10 km typical

Lightning Average Distance	
Range	0–40 km
Resolution	3 km
Accuracy	Variable

COMMUNICATION SPECIFICATIONS

Output	
	SDI-12 communication

Data Logger Compatibility
METER ZL6 and EM60 data loggers or any data acquisition systems capable of switched 3.6- to 15.0-VDC excitation and SDI-12 communication

PHYSICAL SPECIFICATIONS

Dimensions	
Diameter	10 cm (3.94 in)
Height	34 cm (13.38 in), includes rain gauge filter

Operating Temperature Range	
Minimum	-50 °C
Typical	NA
Maximum	60 °C

NOTE: Barometric pressure and relative humidity sensors operate accurately at a minimum of -40 °C.

Cable Length
5 m (standard)
75 m (maximum custom cable length)
NOTE: Contact Customer Support if nonstandard cable length is needed.

Connector Types
3.5-mm stereo plug connector or stripped and tinned wires

ELECTRICAL AND TIMING CHARACTERISTICS

Supply Voltage (VCC to GND)	
Minimum	3.6 VDC continuous
Typical	NA
Maximum	15.0 VDC continuous

NOTE: ATMOS 41 must be continuously powered to work properly.
NOTE: For the ATMOS 41 to meet digital logic levels specified by SDI-12, it must be excited to 3.9 VDC or greater.

Digital Input Voltage (logic high)	
Minimum	2.8 V
Typical	3.6 V
Maximum	5.0 V

Digital Input Voltage (logic low)	
Minimum	-0.3 V
Typical	0.0 V
Maximum	0.8 V

Digital Output Voltage (logic high)	
Minimum	NA
Typical	3.6 V
Maximum	NA

NOTE: For the ATMOS 41 to meet digital logic levels specified by SDI-12, it must be excited to 3.9 VDC or greater.

Power Line Slew Rate	
Minimum	1.0 V/ms
Typical	NA
Maximum	NA

Current Drain (during measurement)	
Minimum	0.2 mA
Typical	8.0 mA
Maximum	33.0 mA

Current Drain (while asleep)	
Minimum	0.2 mA
Typical	0.3 mA
Maximum	0.4 mA

Power Up Time (SDI ready)—aRx! Commands	
Minimum	NA
Typical	10 s
Maximum	NA

Power Up Time (SDI ready)—Other Commands	
Minimum	NA
Typical	310 ms
Maximum	NA

Power Up Time (SDI-12, DDI disabled)	
Minimum	NA
Typical	240 ms
Maximum	NA

Measurement Duration	
Minimum	NA
Typical	110 ms
Maximum	3,000 ms

COMPLIANCE

Manufactured under ISO 9001:2015

EM ISO/IEC 17050:2010 (CE Mark)

EQUIVALENT CIRCUIT AND CONNECTION TYPES

Refer to [Figure 2](#) and [Figure 3](#) to connect the ATMOS 41 to a logger. [Figure 2](#) provides a low-impedance variant of the recommended [SDI-12 specification](#).

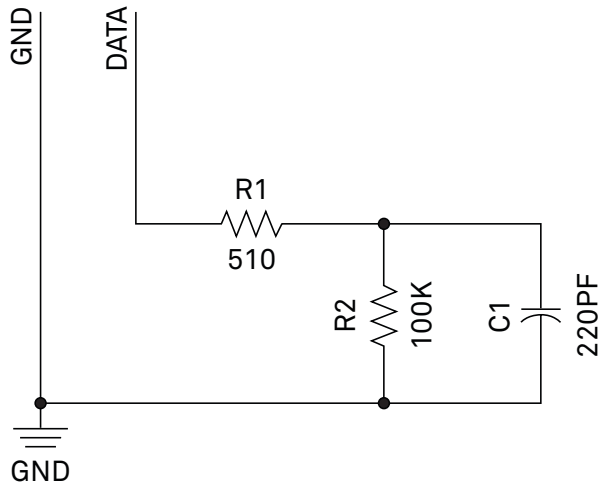
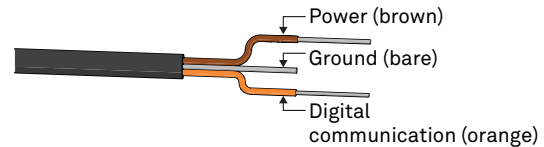

Figure 2 Equivalent circuit diagram

PIGTAIL CABLE



NOTE: Some early ATMOS 41 units may have the older Decagon wiring scheme where the power supply is white, the digital out is red, and the bare wire is ground.

STEREO CABLE

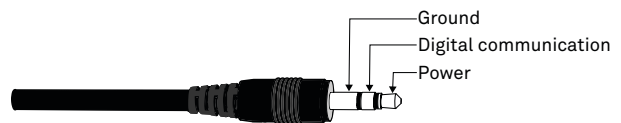

Figure 3 Connection types

PRECAUTIONS

⚠ METER sensors are built to the highest standards, but misuse, improper protection, or improper installation may damage the sensor and possibly void the warranty. Before integrating sensors into a sensor network, follow the recommended installation instructions and implement safeguards to protect the sensor from damaging interference.

SURGE CONDITIONS

Sensors have built-in circuitry that protects them against common surge conditions. Installations in lightning-prone areas, however, require special precautions, especially when sensors are connected to a well-grounded third-party logger.

Visit metergroup.com for articles containing more information.

CABLES

Improperly protected cables can lead to severed cables or disconnected sensors. Cabling issues can be caused by many factors, including rodent damage, driving over sensor cables, tripping over the cable, not leaving enough cable slack during installation, or poor sensor wiring connections. To relieve strain on the connections and prevent loose cabling from being inadvertently snagged, gather and secure the cable travelling between the ATMOS 41 and the data acquisition device to the mounting mast in one or more places. Install cables in conduit or plastic cladding when near the ground to avoid rodent damage. Tie excess cable to the data logger mast to ensure cable weight does not cause sensor to unplug.

SENSOR COMMUNICATIONS

METER digital sensors feature a 3-wire interface following SDI-12 protocol for communicating sensor measurements.

SDI-12 INTRODUCTION

SDI-12 is a standards-based protocol for interfacing sensors to data loggers and data acquisition equipment. Multiple sensors with unique addresses can share a common 3-wire bus (power, ground, and data). Two-way communication between the sensor and logger is possible by sharing the data line for transmit and receive

as defined by the standard. Sensor measurements are triggered by protocol command. The SDI-12 protocol requires a unique alphanumeric sensor address for each sensor on the bus so that a data logger can send commands to and receive readings from specific sensors.

Download the [SDI-12 Specification v1.3](#) and learn more about the SDI-12 protocol.

DDI SERIAL INTRODUCTION

The DDI serial protocol is the method used by the METER family of data loggers for collecting data from the sensor. This protocol uses the data line configured to transmit data from the sensor to the receiver only (simplex). Typically, the receive side is a microprocessor UART or a general-purpose IO pin using a bitbang method to receive data. Sensor measurements are triggered by applying power to the sensor. When the ATMOS 41 is set to address 0, a DDI serial string is sent on power up, identifying the sensor.

INTERFACING THE SENSOR TO A PC

The serial signals and protocols supported by the sensor require some type of interface hardware to be compatible with the serial port found on most personal computers (or USB-to-serial adapters). There are several SDI-12 interface adapters available in the marketplace; however, METER has not tested any of these interfaces and cannot make a recommendation as to which adapters work with METER sensors. METER data loggers and the ZSC and PROCHECK handheld devices can operate as a computer-to-sensor interface for making on-demand sensor measurements. For more information, please contact [Customer Support](#).

METER SDI-12 IMPLEMENTATION

METER sensors use a low-impedance variant of the SDI-12 standard sensor circuit ([Figure 2](#)). During the power-up time, sensors output some sensor diagnostic information and should not be communicated with until the power-up time has passed. After the power up time, the sensors are compatible with all commands listed in the SDI-12 Specification v1.3 except for the continuous measurement commands (aR0–aR9 and aRC0–aRC9) and the concurrent measurement commands (aC–aC9 and aCC0–aCC9). M, R, and C command implementations are found on pages [8–9](#).

Out of the factory, all METER sensors start with SDI-12 address 0 and print out the DDI serial startup string during the power up time. This can be interpreted by non-METER SDI-12 sensors as a pseudo-break condition followed by a random series of bits.

The ATMOS 41 will omit the DDI serial startup string (sensor identification) when the SDI-12 address is nonzero.

ATMOS 41 INTERNAL MEASUREMENT SEQUENCE

Upon power up, the ATMOS 41 initializes an internal timer to 55. This internal timer is incremented by 1 every second and resets to 0 after incrementing to 59. In addition, issuing an averaging command (aM!, aR0!, aR3!, aR7!, and aC!) resets this timer to 55.

While powered up, the ATMOS 41 continuously counts drops from the precipitation sensor and takes solar radiation, wind, and air temperature measurements every 10 s at internal timer intervals of 0, 10, 20, 30, 40, 50 and logs these values internally. Orientation, vapor pressure, atmospheric pressure, and relative humidity are measured every 60 s at the internal timer interval of 4 and logged internally. The aR4! command will output instantaneous measurements of these parameters.

The aM!, aR0!, aR3!, aR7!, and aC! commands (and subsequent D commands when necessary) will compute and output the averages, accumulations, or maximums of these measurements (and derived measurements) and reset internal averaging counters and accumulators. Therefore, it is not necessary to oversample the ATMOS 41 and compute averages, accumulations, and maximums in external data systems. Less frequent sampling has the additional benefit of decreasing data acquisition systems and ATMOS 41 power consumption. If the aM!, aR0!, aR3!, aR7!, and aC! commands are issued more frequently than 2 times their measurement interval, the ATMOS 41 will not average the measurements and will output instantaneous values. The ATMOS 41 has four error codes available: general error code –9999, calibrations lost or corrupt –9992, sensor undervoltage condition –9991, and invalid wind measurement error code –9990.

SDI-12 CONFIGURATION

[Table 1](#) lists the SDI-12 communication configuration.

Table 1 SDI-12 communication configuration

Baud Rate	1,200
Start Bits	1
Data Bits	7 (LSB first)
Parity Bits	1 (even)
Stop Bits	1
Logic	Inverted (active low)

SDI-12 TIMING

All SDI-12 commands and responses must adhere to the format in [Figure 4](#) on the data line. Both the command and response are preceded by an address and terminated by a carriage return line feed combination and follow the timing shown in [Figure 5](#).

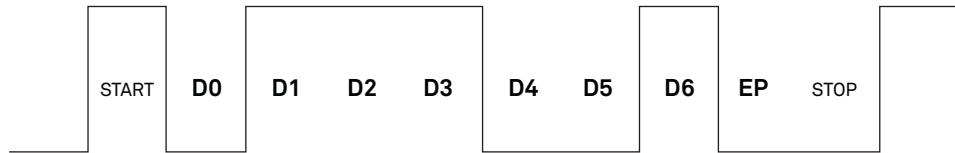

Figure 4 Example SDI-12 transmission of the character 1 (0x31)

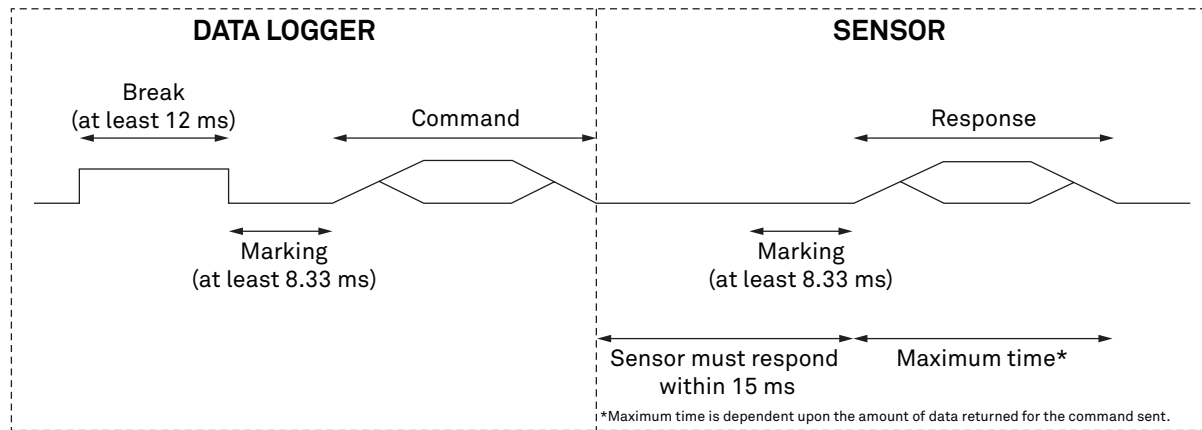

Figure 5 Example data logger and sensor communication

COMMON SDI-12 COMMANDS

This section includes tables of common SDI-12 commands that are often used in an SDI-12 system and the corresponding responses from METER sensors.

IDENTIFICATION COMMAND (aI!)

The Identification command can be used to obtain a variety of detailed information about the connected sensor. An example of the command and response is shown in [Example 1](#), where the command is in **bold** and the response follows the command.

Example 1 1I!113METER_ _ _ _ ATM41_ _ 404631800001

<u>Parameter</u>	<u>Fixed Character Length</u>	<u>Description</u>
1I!	3	Data logger command Request to the sensor for information from sensor address 1.
1	1	Sensor address Prepended on all responses, this indicates which sensor on the bus is returning the following information.
13	2	Indicates that the target sensor supports SDI-12 Specification v1.3
METER_ _ _ _	8	Vendor identification string (METER and three spaces _ _ _ _ for all METER sensors)
ATM41_ _	6	Sensor model string This string is specific to the sensor type. For the ATMOS 41, the string is ATM41_ _.
404	3	Sensor version This number divided by 100 is the METER sensor version (e.g., 404 is version 4.04).
631800001	≤13, variable	Sensor serial number This is a variable length field. It may be omitted for older sensors.

CHANGE ADDRESS COMMAND (aAB!)

The Change Address command is used to change the sensor address to a new address. All other commands support the wildcard character as the target sensor address except for this command. All METER sensors have a default address of 0 (zero) out of the factory. Supported addresses are alphanumeric (i.e., a–z, A–Z, and 0–9). An example output from a METER sensor is shown in [Example 2](#), where the command is in **bold** and the response follows the command.

Example 2 1A0!0

<u>Parameter</u>	<u>Fixed Character Length</u>	<u>Description</u>
1A0!	4	Data logger command Request to the sensor to change its address from 1 to a new address of 0.
0	1	New sensor address. For all subsequent commands, this new address will be used by the target sensor.

ADDRESS QUERY COMMAND (?!)

While disconnected from a bus, the Address Query command can be used to determine which sensors are currently being communicated with. Sending this command over a bus will cause a bus contention where all the sensors will respond simultaneously and corrupt the data line. This command is helpful when trying to isolate a failed sensor. [Example 3](#) shows an example of the command and response, where the command is in **bold** and the response follows the command. The question mark (?) is a wildcard character that can be used in place of the address with any command except the Change Address command.

Example 3 ?!0

<u>Parameter</u>	<u>Fixed Character Length</u>	<u>Description</u>
?!	2	Data logger command Request for a response from any sensor listening on the data line
0	1	Sensor address. Returns the sensor address to the currently connected sensor.

COMMAND IMPLEMENTATION

The following tables list the relevant Measurement (M), Continuous (R), Concurrent (C), and Verification (V) commands and subsequent Data (D) commands when necessary.

MEASUREMENT COMMANDS IMPLEMENTATION

Measurement (M) commands are sent to a single sensor on the SDI-12 bus and require that subsequent Data (D) commands are sent to that sensor to retrieve the sensor output data before initiating communication with another sensor on the bus.

Please refer to [Table 2](#) and [Table 3](#) for an explanation of the command sequence and see [Table 10](#) for an explanation of response parameters.

Table 2 aM! command sequence

Command	Response
This command reports average, accumulated, or maximum values. Please see ATMOS 41 Internal Measurement Sequence for more details.	
aM!	atttn
aD0!	a<solar>+<precipitation>+<strikes>
aD1!	a<windSpeed>+<windDirection>+<gustWindSpeed>
aD2!	a±<airTemperature>+<vaporPressure>+<atmosphericPressure>

NOTE: The measurement and corresponding data commands are intended to be used back to back. After a measurement command is processed by the sensor, a service request a <CR><LF> is sent from the sensor signaling the measurement is ready. Either wait until *ttt* seconds have passed or wait until the service request is received before sending the data commands. See the [SDI-12 Specifications v1.3](#) document for more information.

Table 3 aM1! command sequence

Command	Response
This command reports instantaneous values.	
aM1!	atttn
aD0!	a±<xOrientation>±<yOrientation>+<nullValue>

NOTE: The measurement and corresponding data commands are intended to be used back to back. After a measurement command is processed by the sensor, a service request a <CR><LF> is sent from the sensor signaling the measurement is ready. Either wait until *ttt* seconds have passed or wait until the service request is received before sending the data commands. See the [SDI-12 Specifications v1.3](#) document for more information.

CONTINUOUS MEASUREMENT COMMANDS IMPLEMENTATION

Continuous (R) measurement commands trigger a sensor measurement and return the data automatically after the readings are completed without needing to send a D command.

The aR4! command must be used at intervals of 10 s or greater for the response to be returned within 15.0 ms as defined in the SDI-12 standard.

aR0!, aR3!, and aR4! return more characters in their responses than the 75-character limitation called out in the [SDI-12 Specification v1.3](#). It is recommended to use a buffer that can store at least 116 characters.

Please refer to [Table 4](#) through [Table 7](#) for an explanation of the command sequence and see [Table 10](#) for an explanation of response parameters.

Table 4 aR0! measurement command sequence

Command	Response
This command reports average, accumulated, or maximum values. Please see ATMOS 41 Internal Measurement Sequence for more details regarding timing of this command.	
aR0!	a<solar>+<precipitation>+<strikes>+<strikeDistance>+<windSpeed> +<windDirection>+<gustWindSpeed>±<airTemperature>+<vaporPressure> +<atmosphericPressure>+<relativeHumidity>±<humiditySensorTemperature> ±<xOrientation>±<yOrientation>+<nullValue>±<NorthWindSpeed> ±<EastWindSpeed>

NOTE: This command does not adhere to the SDI-12 response format. See [METER SDI-12 Implementation](#) for more information.

Table 5 aR3! measurement command sequence

Command	Response
This command reports average, accumulated, or maximum values. Please see ATMOS 41 Internal Measurement Sequence for more details.	
aR3!	a<TAB><solar> <precipitation> <strikes> <strikeDistance> <NorthWindSpeed> <EastWindSpeed> <gustWindSpeed> <airTemperature> <vaporPressure> <atmosphericPressure> <xOrientation> <yOrientation> <nullValue> <humiditySensorTemperature><CR><sensorType><Checksum><CRC>
NOTE: This command does not adhere to the SDI-12 response format. However, it does adhere to SDI-12 timing if it is sent at intervals >10 s. See METER SDI-12 Implementation for more information. The values in this command are space delimited. As such, a + sign is not assigned between values and a - sign is only present if the value is negative.	

Table 6 aR4! measurement command sequence

Command	Response
This command reports instantaneous values.	
aR4!	a<TAB><solar> <precipitation> <strikes> <strikeDistance> <NorthWindSpeed> <EastWindSpeed> <gustWindSpeed> <airTemperature> <vaporPressure> <atmosphericPressure> <xOrientation> <yOrientation> <nullValue> <humiditySensorTemperature><CR><sensorType><Checksum><CRC>
NOTE: This command does not adhere to the SDI-12 response format or timing. See METER SDI-12 Implementation for more information. The values in this command are space delimited. As such, a + sign is not assigned between values and a - sign is only present if the value is negative.	

Table 7 aR7! measurement command sequence

Command	Response
This command reports average, accumulated, or maximum values. Please see ATMOS 41 Internal Measurement Sequence for more details regarding timing of this command.	
aR7!	a+<solar>+<precipitation>+<strikes>+<strikeDistance>+<windSpeed> +<windDirection>+<gustWindSpeed>±<airTemperature>+<vaporPressure> +<atmosphericPressure>+<relativeHumidity>±<humiditySensorTemperature> ±<xOrientation>±<yOrientation>
NOTE: See METER SDI-12 Implementation for more information.	

CONCURRENT MEASUREMENT COMMANDS IMPLEMENTATION

Concurrent (C) measurement commands are typically used with sensors connected to a bus. Measurements are initiated with a C command and subsequent D commands are sent to the sensor to retrieve the readings.

Please refer to [Table 8](#) for an explanation of the command sequence and see [Table 10](#) for an explanation of response parameters.

Table 8 aC! measurement command sequence

Command	Response
This command reports average, accumulated, or maximum values. Please see ATMOS 41 Internal Measurement Sequence for more details.	
aC!	atttn
aD0!	a+<solar>+<precipitation>+<strikes>+<strikeDistance>
aD1!	a+<windSpeed>+<windDirection>+<gustWindSpeed>
aD2!	a±<airTemperature>+<vaporPressure>+<atmosphericPressure>+<relativeHumidity>± <humiditySensorTemperature>
aD3!	a±<xOrientation>±<yOrientation>+<nullValue>
aD4!	a±<NorthWindSpeed>±<EastWindSpeed>+<gustWindSpeed>
NOTE: Please see the SDI-12 Specifications v1.3 document for more information.	

VERIFICATION COMMAND IMPLEMENTATION

The Verification (V) command is intended to give users a means to determine information about the current state of the sensor. The V command is sent first, followed by D commands to read the response.

Please refer to [Table 9](#) for an explanation of the command sequence and [Table 10](#) for an explanation of those response parameters.

Table 9 aV! measurement command sequence

Command	Response
aV!	attnn
aD0!	a+<meta>

NOTE: Please see the [SDI-12 Specifications v1.3](#) document for more information.

PARAMETERS

[Table 10](#) lists the parameters, unit measurement, and a description of the parameters returned in command responses for ATMOS 41.

Table 10 Parameter Descriptions

Parameter	Unit	Description
±	—	Positive or negative sign denoting sign of the next value
a	—	SDI-12 address
n	—	Number of measurements (fixed width of 1)
nn	—	Number of measurements with leading zero if necessary (fixed width of 2)
ttt	s	Maximum time measurement will take (fixed width of 3)
<TAB>	—	Tab character
<CR>	—	Carriage return character
<LF>	—	Line feed character
<solar>	W/m ²	Solar radiation (average since the last measurement or instantaneous value depending on SDI-12 command used)
<precipitation>	mm	Rainfall since the last measurement
<strikes>	—	Number of lightning strikes detected since last measurement
<strikeDistance>	km	Average strike distance from sensor since last measurement
<NorthWindSpeed>	m/s	Wind speed from the northerly direction (negative values denote southerly direction) (average since the last measurement or instantaneous value depending on SDI-12 command used)
<EastWindSpeed>	m/s	Wind speed from the easterly direction (negative values denote westerly direction) (average since the last measurement or instantaneous value depending on SDI-12 command used)
<windSpeed>	m/s	Combined wind speed magnitude of the <NorthWindSpeed> and <EastWindSpeed> (average since the last measurement or instantaneous value depending on SDI-12 command used)
<gustWindSpeed>	m/s	Maximum measured <windSpeed> since the last measurement
<windDirection>	°	Wind heading clockwise from north reference (average since the last measurement or instantaneous value depending on SDI-12 command used)
<airTemperature>	°C	Air temperature (average since the last measurement or instantaneous value depending on SDI-12 command used)
<vaporPressure>	kPa	Vapor pressure (average since the last measurement or instantaneous value depending on SDI-12 command used)

Table 9 Parameter Descriptions (continued)

Parameter	Unit	Description
<atmosphericPressure>	kPa	Atmospheric pressure (average since the last measurement or instantaneous value depending on SDI-12 command used)
<relativeHumidity>	RH	Relative humidity as a dimensionless fraction computed with either average or instantaneous values of <vaporPressure> and <airTemperature>, depending on SDI-12 command used
<humiditySensor Temperature>	°C	Internal temperature measured with the relative humidity sensor (average since the last measurement or instantaneous value depending on SDI-12 command used)
<xOrientation>	°	X orientation angle (0 is level) (last measured value)
<yOrientation>	°	Y orientation angle (0 is level) (last measured value)
<nullValue>	—	This parameter is reported as 0. Previous firmware versions reported a compass heading, which has been removed.
<meta>	—	Auxiliary sensor information. See Table 11 .
<sensorType>	—	ASCII character denoting the sensor type For ATMOS 41, the character is the right square bracket] character
<Checksum>	—	METER serial checksum
<CRC>	—	METER serial 6-bit CRC

SENSOR METADATA VALUE

The sensor metadata value contains information to help alert users to sensor-identified conditions that may compromise optimal sensor operation. The output of the aV! aD0! sequence will output a <meta> integer value. This integer represents a binary bitfield, with each individual bit representing an error flag.

[Table 11](#) lists the possible error flags that can be set by the TEROS 21. If multiple error flags are set, the sensor metadata integer value will be the sum of the individual values. To decode an integer value not explicitly in [Table 11](#), find the largest error flag value that will fit in the integer value and accept that error as being present. Then, subtract that error flag value from the integer value and repeat the process on the remainder until the result is zero. For example, a sensor metadata integer value of 208 is the sum of the individual error flag values 128+64+16, so this sensor sensor secondary temperature measurement error flag, sensor firmware corrupt error flag, and the sensor misorientation error flag.

Table 11 Error flag values and issue resolution

Error Flag Value	Issue Present	Resolution
0	No issue present	—
16	Sensor misorientation error will likely affect readings	Use the ZENTRA Utility app to reorient the X orientation or Y orientation of the sensor.
64	Sensor thermistor is broken and sensor is using a backup measurement	Contact Customer Support . Irreversible sensor damage is likely.
128	Sensor firmware is corrupt	Contact Customer Support for instructions on reloading firmware.
256	Sensor calibrations lost or corrupted	Contact Customer Support for instructions on reloading sensor calibrations.

DDI SERIAL CHECKSUM

These checksums are used in the continuous commands R3 and R4 as well as DDI serial response. The legacy checksum is computed from the start of the transmission to the sensor identification character.

Legacy checksum example input is `<TAB>0 0.000 1 1 0.22 0.21 0.30 24.3 1.26 92.74 -1.5 -4.0 0 24.4<CR>` and the resulting checksum output is A.

```
char LegacyChecksum(char * Response)
{
    int length, sum = 0, i, crc;

    // Finding the length of the response string
    length = strlen(Response);

    // Adding characters in the response together
    for( i = 0; i < length; i++){
        sum += Response[i];
    }

    // Converting checksum to a printable character
    crc = sum % 64 + 32;

    return crc;
}
```

The more robust CRC6, supported in firmware version 4.61 or newer, utilizes the CRC-6-CDMA2000-A polynomial with the value 48 added to the results to make this a printable character and is computed from the start of the transmission to the legacy checksum character.

CRC6 checksum example input is `<TAB>0 0.000 1 1 0.22 0.21 0.30 24.3 1.26 92.74 -1.5 -4.0 0 24.4<CR>` and the resulting checksum is the character h.

```

uint8_t CRC6_Offset (uint8_t * buffer, uint16_t bytes)
{
    uint16_t byte;
    uint8_t bit;
    uint8_t crc = 0xfc; // Set upper 6 bits to 1's

    // Loop through all the bytes in the buffer
    for(byte = 0; byte < bytes; byte++)
    {

        // Get the next byte in the buffer and XOR it with the crc
        crc ^= buffer[byte];

        // Loop through all the bits in the current byte
        for(bit = 8; bit > 0; bit--)
        {
            // If the uppermost bit is a 1...
            if(crc & 0x80)
            {
                // Shift to the next bit and XOR it with a polynomial
                crc = (crc << 1) ^ 0x9c;
            }
            else
            {
                // Shift to the next bit
                crc = crc << 1;
            }
        }
    }

    // Shift upper 6 bits down for crc
    crc = (crc >> 2);

    // Add 48 to shift crc to printable character avoiding \r \n and !
    return (crc + 48);
}

```

CUSTOMER SUPPORT

NORTH AMERICA

Customer service representatives are available for questions, problems, or feedback Monday through Friday, 7:00 am to 5:00 pm Pacific time.

Email: support.environment@metergroup.com
sales.environment@metergroup.com

Phone: +1.509.332.5600

Fax: +1.509.332.5158

Website: metergroup.com

EUROPE

Customer service representatives are available for questions, problems, or feedback Monday through Friday, 8:00 to 17:00 Central European time.

Email: support.europe@metergroup.com
sales.europe@metergroup.com

Phone: +49 89 12 66 52 0

Fax: +49 89 12 66 52 20

Website: metergroup.de

If contacting METER by email, please include the following information:

Name	Email address
Address	Instrument serial number
Phone number	Description of problem

NOTE: For products purchased through a distributor, please contact the distributor directly for assistance.

REVISION HISTORY

The following table lists document revisions.

Revision	Date	Compatible Firmware	Description
08	7.31.2020	5.30	Added Verification command implementation. Updated specifications.
07	1.24.2020	5.01	Removed Sensor Bus Considerations. Corrected Tables 5, 6, and 7.
06	8.9.2019	5.01	Added explanation of when measurements are taken. Updated specifications.
05	10.31.2018	4.67	Modified bus configurations
04	7.16.2018	4.67	Added R7 command. Modified R0 command note.
03	6.5.2018	4.65	Increased temperature range. Modified digital input voltage logic high specifications. Removed reference to compass.
02	12.7.2017	4.61	Updated specifications.
01	9.15.2017	4.61	Added Concurrent (C) command. Reduced wind speed specification. Added CRC6.
00	10.27.2017	4.49	Initial release.